

UNYCO GALAXY



Galaxy UNYCO Diaphyseal Tibia Sterile Kit

Key contributors:
S. Nayagam, MD
T. Bégué, MD
W.T. Gordon, MD

1	INTRODUCTION
1	INDICATIONS
2	MAIN FEATURES
5	EQUIPMENT REQUIRED
6	UNYCO SCREW INSERTION

**Orthofix wishes to thank
the following surgeons for their contribution
to the development of the technique:**

**S. NAYAGAM, MD
T. BÉGUÉ, MD
W. T. GORDON, MD**

INTRODUCTION

Rapid skeletal stabilisation with external fixation is used for some severe high energy tibial fractures, especially in those with multiple injuries or from combat or natural disaster scenarios. This damage control surgery is part of a staged protocol where the temporary external fixation is an emergency procedure to be followed by definitive fracture fixation when conditions allow. In these scenarios, the external fixator has to be stable, versatile and quick to apply. Tibia fractures with severe soft tissue injuries present several problems due to contamination, loss of soft-tissue support, and disruption of the periosteal blood supply (Maurer, Yokoyama, Bhandari). These fractures are associated with high rates of complications including deep infection (Papakostidis, Chua, Bhandari).

The management of open tibial fractures continue to challenge orthopaedic, plastic and vascular surgeons (Chua).

The Galaxy UNYCO Diaphyseal Tibia Sterile Kit is an external fixation system conceived for temporary stabilization of tibial fractures, achieving excellent stability but without the screws perforating the medullary canal.

The whole system offers the following unique benefits:

For the patients:

- Designed to avoid contamination of the medullary canal
- Designed for a minimally invasive approach
- Designed to facilitate the conversion from temporary to definitive fixation
- In case of polytrauma and emergency situations, quick fracture stabilization procedures may positively influence lifesaving outcomes

For the surgeons:

- Fewer steps in the operative technique
- Designed to facilitate the conversion from temporary to definitive fixation
- Designed to avoid contamination of the medullary canal
- Completely compatible with the Galaxy external fixator system, thereby enabling additional injuries of the lower limb to be stabilised and linked to the UNYCO assembly
- Simplicity in application enabling rapid familiarity and mastery of the system

For the hospital:

- Designed to allow a minimally invasive approach which may optimize OR time and result in cost savings
- Prepacked sterile kits enabling efficient inventory management, better traceability and reduced logistic costs

References

- Kulshrestha V.* Incidence of infection after early intramedullary nailing of open tibial shaft fractures stabilized with pinless external fixators. *Indian J Orthop.* 2008 Oct;42(4):401-9.
- Schütz M, Sudkamp N, Frigg R, Hoffman R, Stockle U, Haas N.* Pinless external fixation: Indications and preliminary results in tibial shaft fractures. *Clin Orthop Relat Res.* 1998;347:35-42.
- Maurer DJ, Merkow RL, Gustilo RB.* Infection after intramedullary nailing of severe open tibial fractures initially treated with external fixation. *J Bone Joint Surg Am.* 1989 Jul;71(6):835-8.
- Yokoyama K, Uchino M, Nakamura K, Ohtsuka H, Suzuki T, Boku T, Itoman M.* Risk factors for deep infection in secondary intramedullary nailing after external fixation for open tibial fractures. *Injury.* 2006 Jun;37(6):554-60.
- Bhandari M, Guyatt GH, Swiontkowski MF, Schemitsch EH.* Treatment of open fractures of the shaft of the tibia. *J Bone Joint Surg Br.* 2001 Jan;83(1):62-8.
- Papakostidis C, Kanakaris NK, Pretel J, Faour O, Morell DJ, Giannoudis PV.* Prevalence of complications of open tibial shaft fractures stratified as per the Gustilo-Anderson classification. *Injury.* 2011 Dec;42(12):1408-15.
- Chua W, Murphy D, Siow W, Kagda F, Thambiah J.* Epidemiological analysis of outcomes in 323 open tibial diaphyseal fractures: a nine-year experience. *Singapore Med J.* 2012 Jun;53(6):385-9.

INDICATIONS

The Galaxy UNYCO Diaphyseal Tibia Kit is intended to be used to provide bone stabilization in trauma, specifically lower limb fractures, that require temporary fixation prior to definitive treatment.

The product is indicated for non weight-bearing use.

The indications for use include:

- Tibial fractures extending from about 8cm below the knee to about 7 cm above the ankle joint, including comminuted open or closed tibial fractures and polytrauma.
- Temporary stabilisation of the tibia after debridement for osteomyelitis or an infected non-union pending second stage treatment.

MAIN FEATURES

UNYCO SCREWS



Code	Description
93507	UNYCO Screw QC Shaft Ø 6mm



Code	Description
93508	UNYCO Cancellous Screw QC Shaft Ø 6mm



UNYCO Cancellous Screw



UNYCO Screw



UNYCO Cancellous Screw

There are two variants of the UNYCO screw: one designed for diaphyseal bone (UNYCO screw) and one for metaphyseal bone (UNYCO Cancellous Screw). If the surgeon is working in an area that is meta-diaphyseal and is uncertain as to which screw should be applied, the choice should be for the UNYCO Cancellous type as the torque limiter will prevent over-penetration should there be sufficient quality of the cortical bone in that area. If the bone quality is insufficient, the surgeon can adjust by stopping the drilling as soon as the groove (soft tissue reference line) on the screw reaches the skin edge.



Large Multiscrew Clamp for UNYCO Screws

The clamp is provided in M configuration, but it can be easily converted to U configuration by unlocking the arms with the universal Allen wrench and by re-positioning them (see below). This feature makes the system flexible and versatile.

How to change configuration

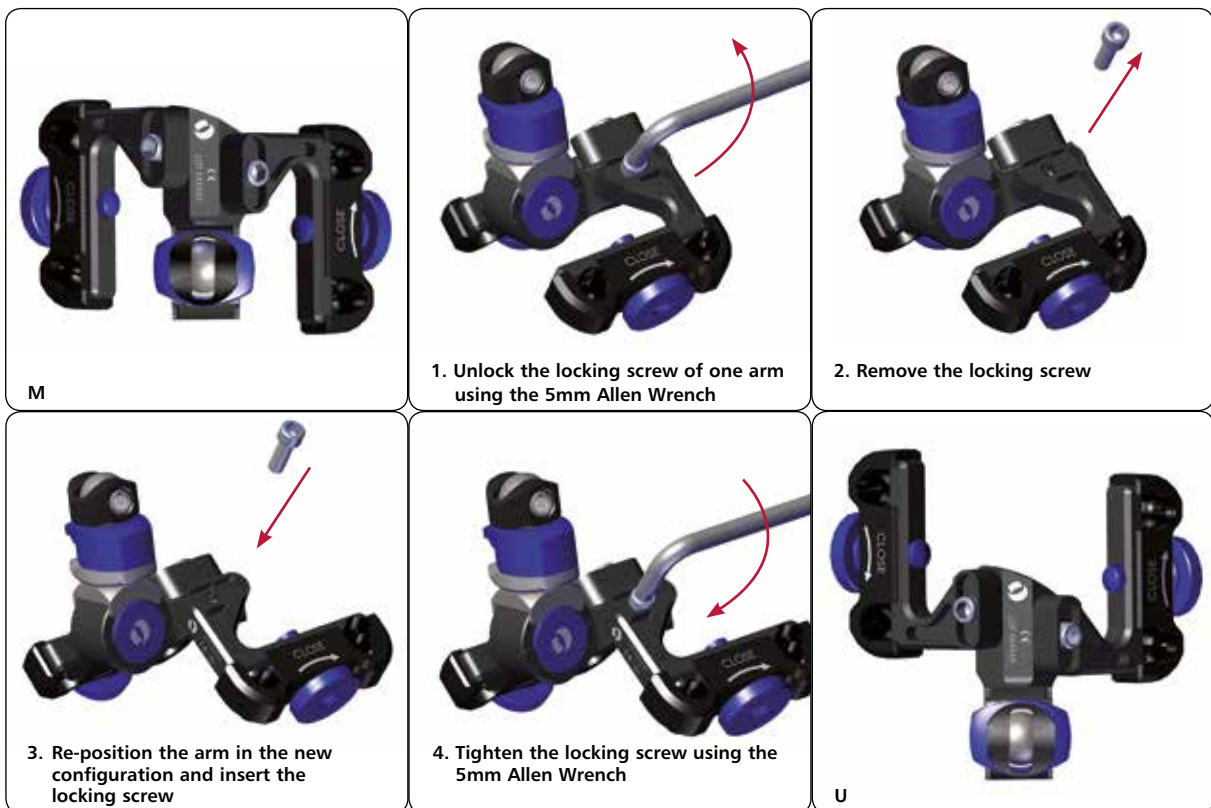

Repeat the above mentioned steps 1- 4 to position the second arm.

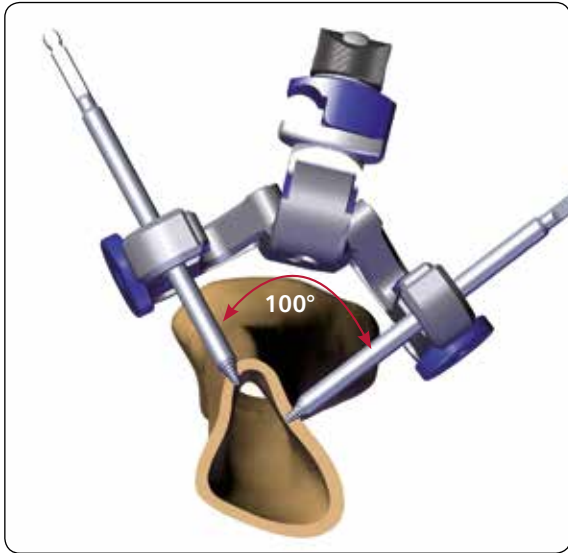

The two arms subtend a 100 degree arc which facilitates screw insertion perpendicular to the bone surface.

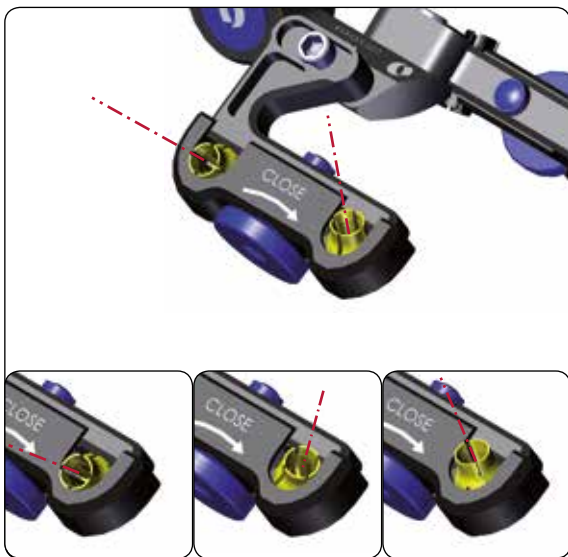

The screw seats allow $\pm 10^\circ$ variable angle screw positioning so that screws can be oriented independently.

EQUIPMENT REQUIRED

STERILE KIT

99-93506 Galaxy UNYCO Diaphyseal Tibia Sterile Kit

Consisting of:

Code	Description
2x93566	Large Multiscrew Clamp for UNYCO Screws
1x932350	Galaxy Rod Ø 12mm L 350mm
8x93507	UNYCO Screw QC Shaft Ø 6mm
4x93508	UNYCO Cancellous Screw QC Shaft Ø 6mm
1x30017	Allen Wrench 5mm
1x99-93568	Power Drill Torque Limiter



Power Drill Torque Limiter

99-93567 Limited Torque Wrench (out of Kit - available upon request)

To be used for inserting the screws by hand.



UNYCO SCREW INSERTION

- 1) Make a 5mm puncture in the skin (Fig. 1).

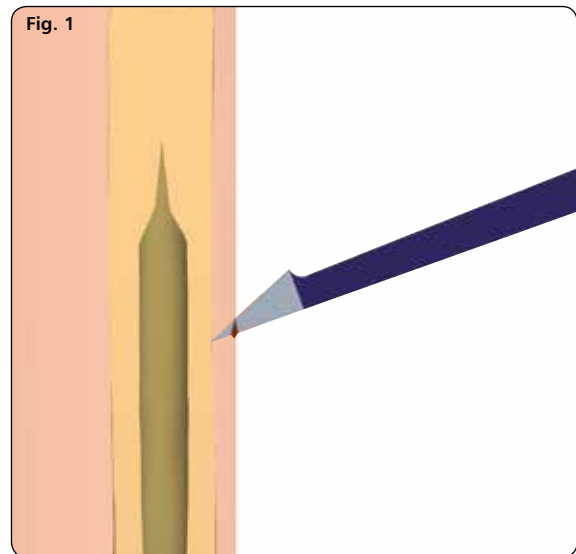

WARNING:

When working in the metaphyseal area (proximal or distal tibia), it is advisable to use the UNYCO Cancellous Screw which provides the assurance of either torque limiter-guided penetration depth or a visual check by the surgeon of the groove on the screw (soft tissue reference line) against the skin surface.



- 2) Insert the first screw freehand, without the clamp, directly over the tibial crest (Fig. 2a) or medial or lateral (Fig. 2b) to it and check its correct position on the bone. Always attempt a perpendicular placement of the screw on the bone surface.

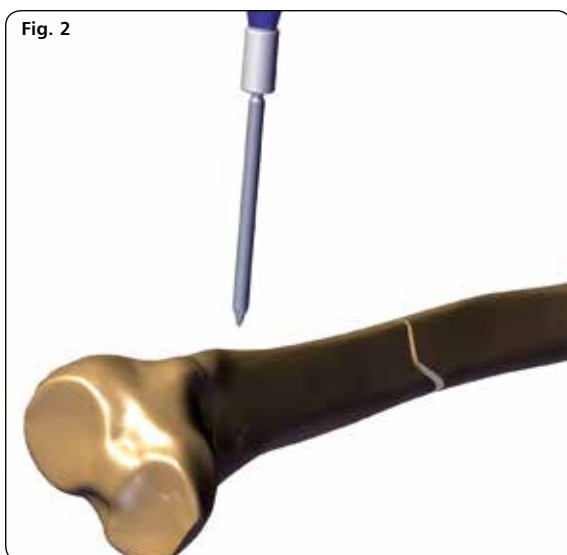

Screw Insertion

- 3) Drill the screw perpendicular to the bone surface using a low speed power drill with the Power Drill Torque Limiter already mounted.

In **Cancellous Bone**, where the UNYCO Cancellous Screws should be used, drilling is stopped when the soft tissue reference line reaches the skin (Fig. 3a). There will be instances when the cortex of the cancellous bone is sufficiently hard such that the torque limiter will activate on reaching the required torque and decouple the drilling. The UNYCO Cancellous screw has been designed such that the first 5mm is similar in design to the standard UNYCO Screw and so will function to the same mechanical performance. If the torque level is not reached owing to a softer cortex in this area, the surgeon has the ability to stop further penetration when the groove on the screw (soft tissue reference line) reaches the skin surface.

In **Cortical Bone**, when the screw is correctly inserted into the first cortex, the Power Drill Torque Limiter will stop the rotation of the screw automatically (Fig. 3b).

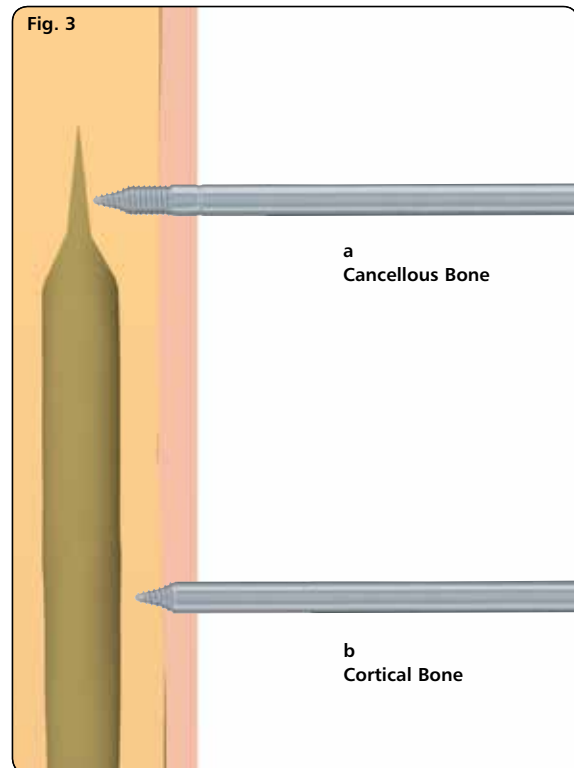

Apply the Large Multiscrew Clamp for UNYCO Screws (93566) on the first screw and tighten the metal ring on the arm clockwise (Fig. 4).

NOTE: Once converging screws have been inserted, the clamps can no longer slide on the screw shafts. It is therefore important to determine the final distance (of 40mm or approximately 2 fingers breadth) of the clamp from the skin before inserting the second screw. Ideally, the clamp should be positioned at a distance of 40mm from the skin (Fig. 5).

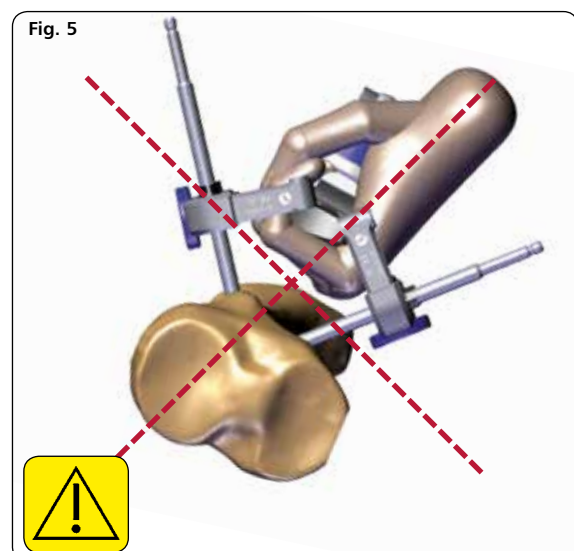
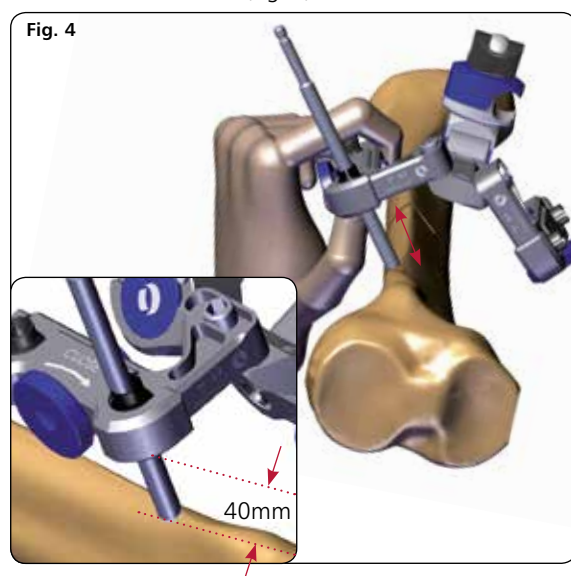

- Using the Galaxy UNYCO Tibia Clamp (93566) as a template for screw insertion, insert the second screw in the contralateral arm, trying to be as perpendicular as possible to the bone surface. Check its correct position on the bone and if necessary partially tighten the metal ring on the arm clockwise so that the screw within its seat is free to move but without excessive play.

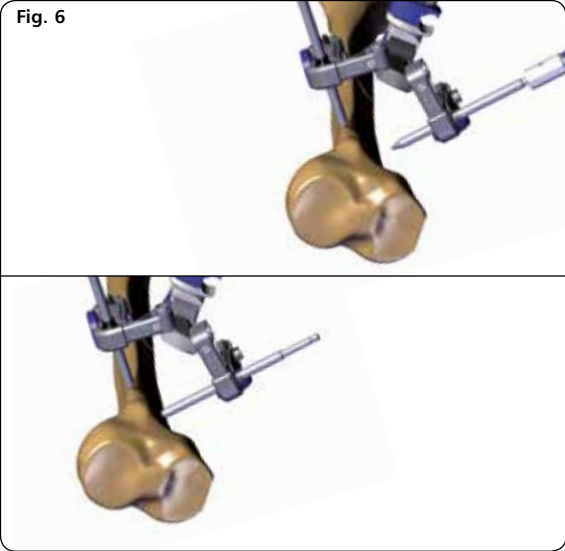

WARNING:

The system stability is guaranteed only with a minimum of 3 screws (2 of them must be UNYCO screws 93507) coupled with the Large Multiscrew Clamp for UNYCO Screws in each bone segment. The use of four screws is to be preferred. When working in the metaphyseal area, the use of 4 screws is recommended.

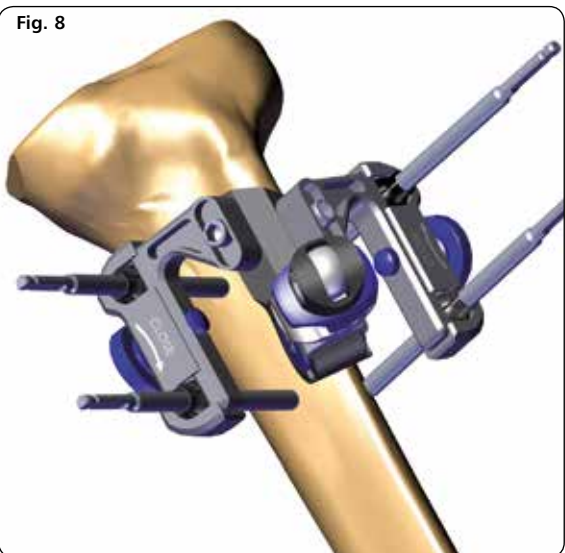
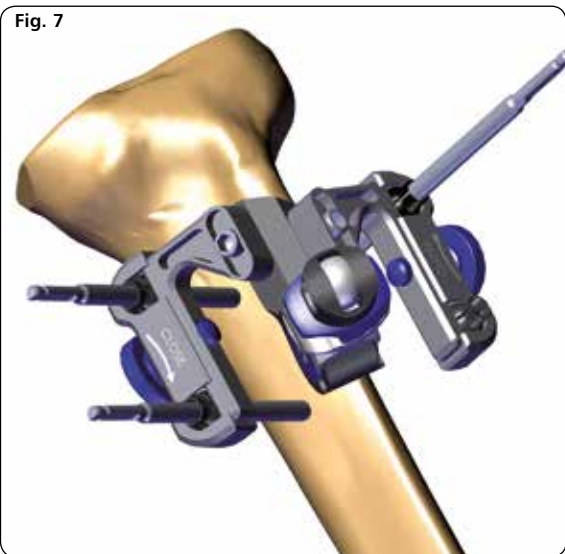

- 5) Once all screws in each arm have been inserted, tighten both metal rings fully with the 5mm Allen Wrench (30017) (Fig. 9).

Fig. 9

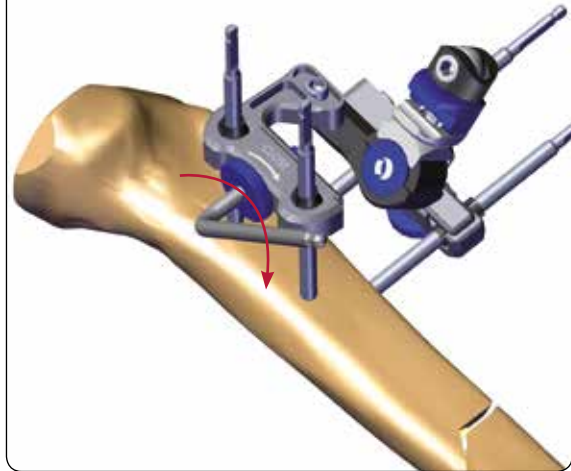

- 6) Follow steps 2-5 to apply the second Large Multiscrew Clamp for UNYCO Screws in the distal segment (Fig. 10).

Fig. 10

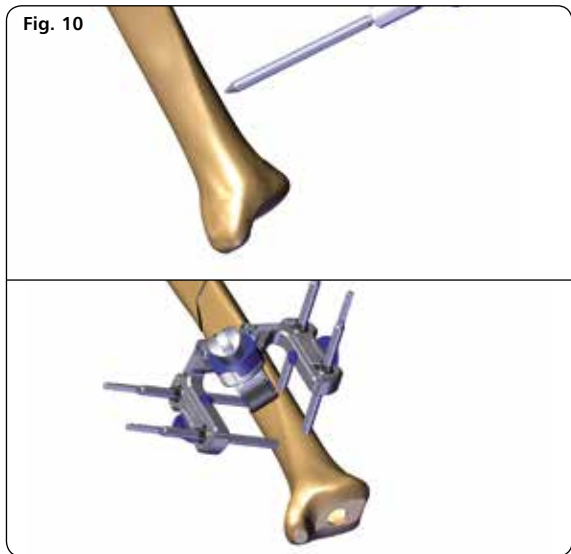

- 7) Join both Large Multiscrew Clamps for UNYCO Screws with the rod leaving the clamps loosened to facilitate fracture reduction (Fig. 11).

Fig. 11



- 8) Reduce the fracture, with X-ray guidance as necessary, holding the clamps to facilitate the reduction manoeuvre (Fig. 12).

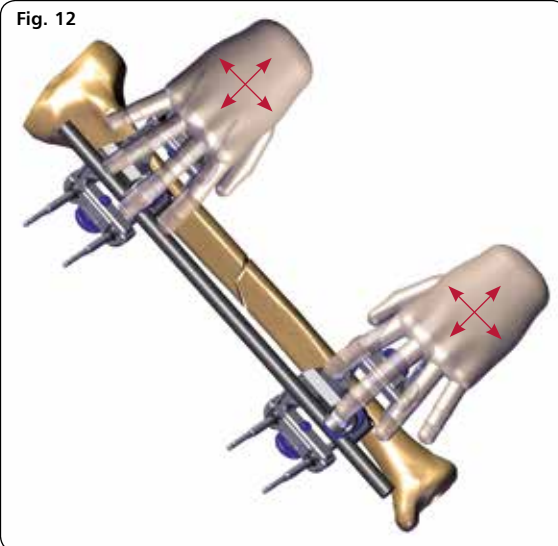

- 9) Lock the clamps first manually by turning the knurled metal ring clockwise (Fig. 13).

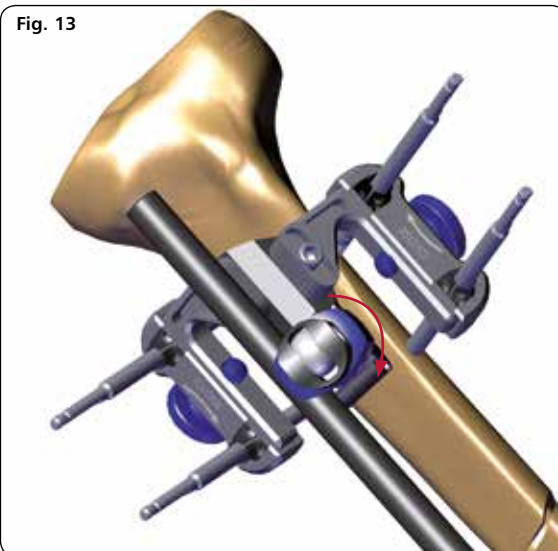

- 10) If reduction is satisfactory, finally lock all the clamps firmly by tightening the cams with the 5mm Allen Wrench (Fig. 14).

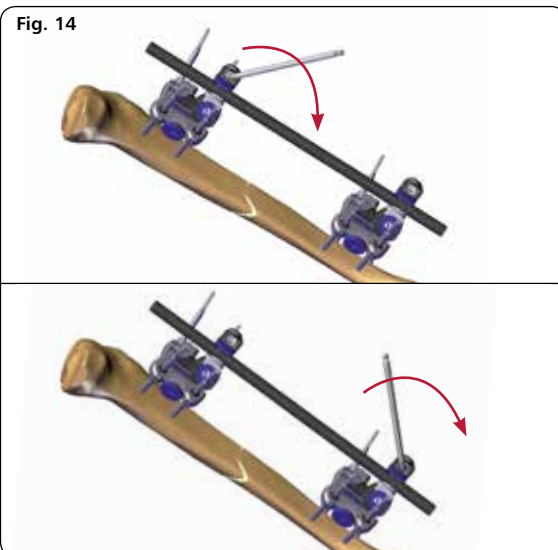

In case of a segmental fracture, the middle segment can be stabilised using a UNYCO Screw in a Galaxy Large Clamp (93010) attached to the same connecting rod that links the two Large Multiscrew Clamps for UNYCO Screws.

Before drilling the UNYCO Screw into the bone, partially tighten the metal ring on the clamp clockwise so that the screw within its seat is free to move but without excessive play. Once the screw has been inserted, tighten the clamp by hand (Fig. 15).

Fig. 15

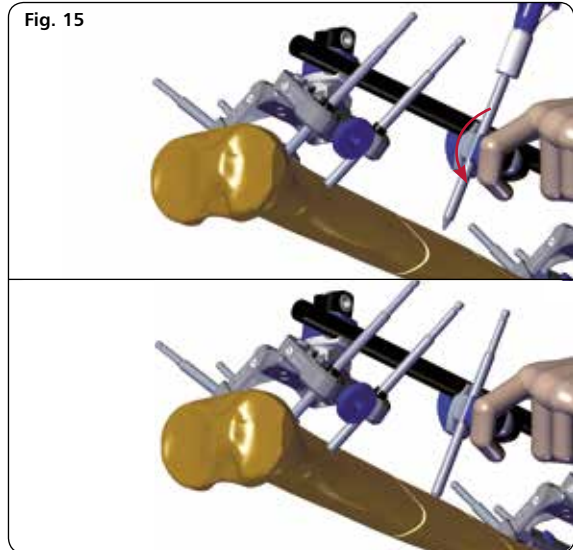

Finally, lock the clamp with the Allen Wrench (30017) (Fig. 16).

Fig. 16

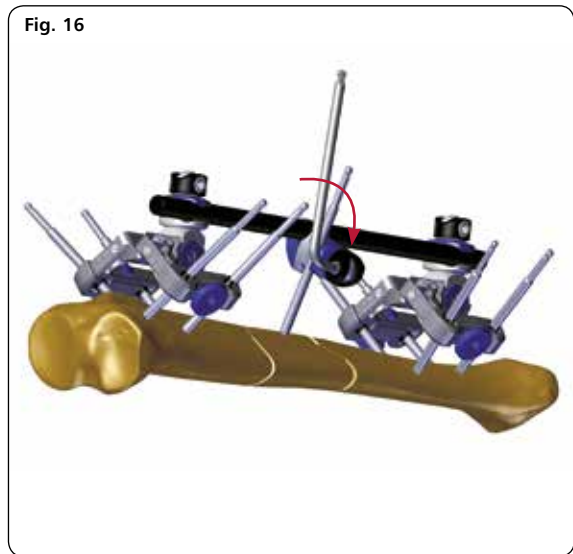

CHANGING TO DEFINITIVE TREATMENT

If the system is perceived as impediment for the correct definitive treatment application, remove the SYSTEM PARTS where needed. For instance, if there was a need to insert a plate on the medial side but maintain the overall reduction and alignment:

- 1) Unlock the metal ring of the medial arm of the proximal Large Multiscrew Clamp for UNYCO Screws (Fig. 17).

Fig. 17

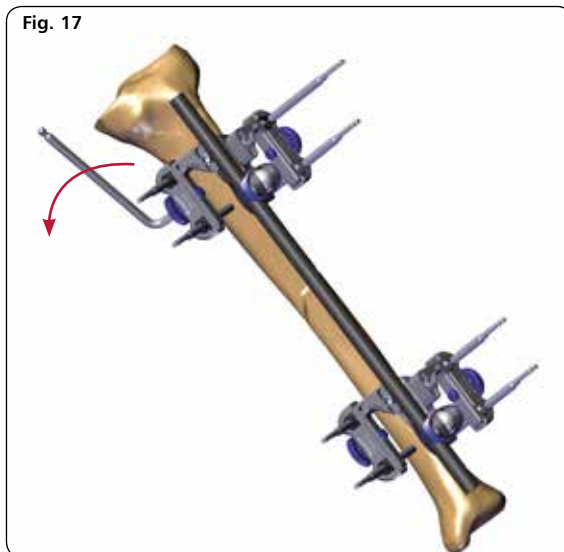

- 2) Remove the UNYCO screws (Fig. 18).

Fig. 18

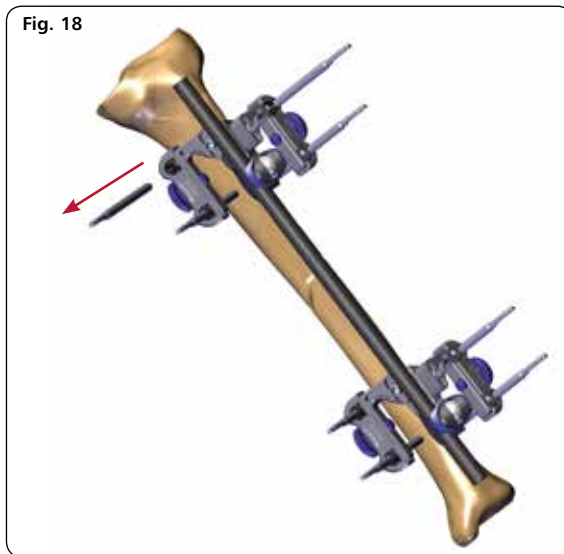

- 3) Unlock the locking screw of the medial arm with the 5mm Allen Wrench (Fig. 19).

Fig. 19

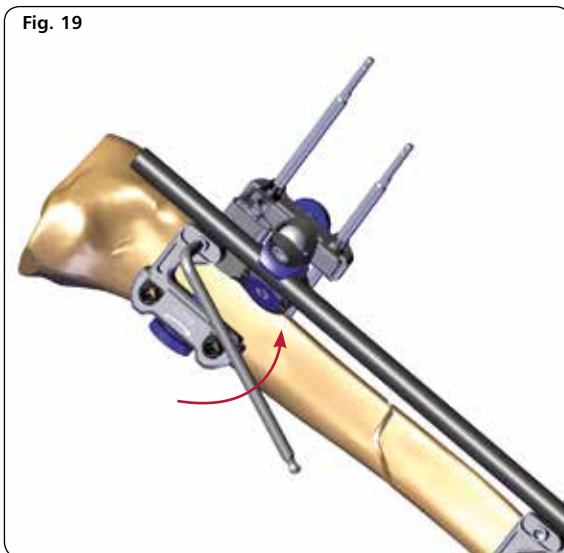

- 4) Remove the medial arm (Fig. 20).

Fig. 20

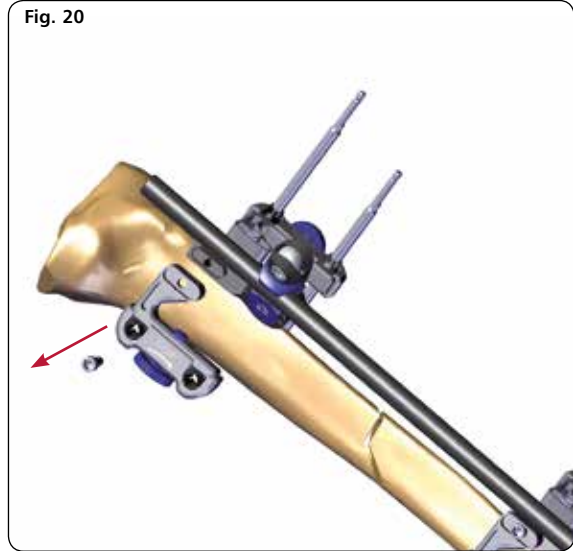

- 5) If necessary repeat the procedure with the distal clamp (Fig. 21).

Fig. 21

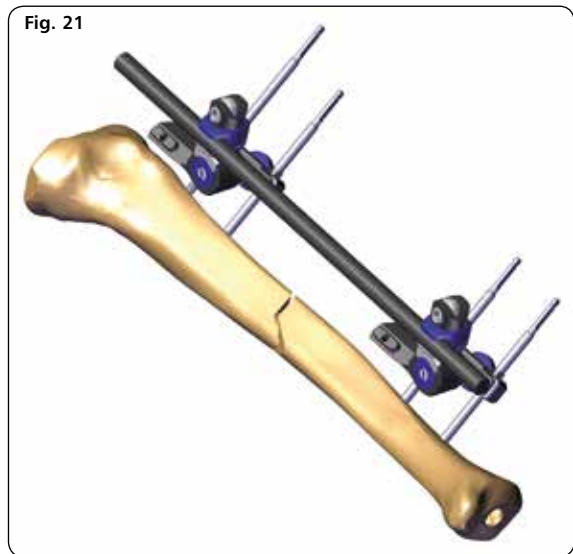

In a similar fashion, if lateral submuscular plating was intended for the fracture, the lateral arms could be removed instead. In both scenarios described above, it is imperative there are 4 screws in each Large Unyco Clamp before any arm is disconnected.

If intramedullary nailing of the fracture is envisaged as definitive treatment, it is usually not necessary to remove the fixator at all. However, appropriate sterile precautions would need to be taken to seal off the fixator from the remainder of the operative field.

DAMAGE CONTROL

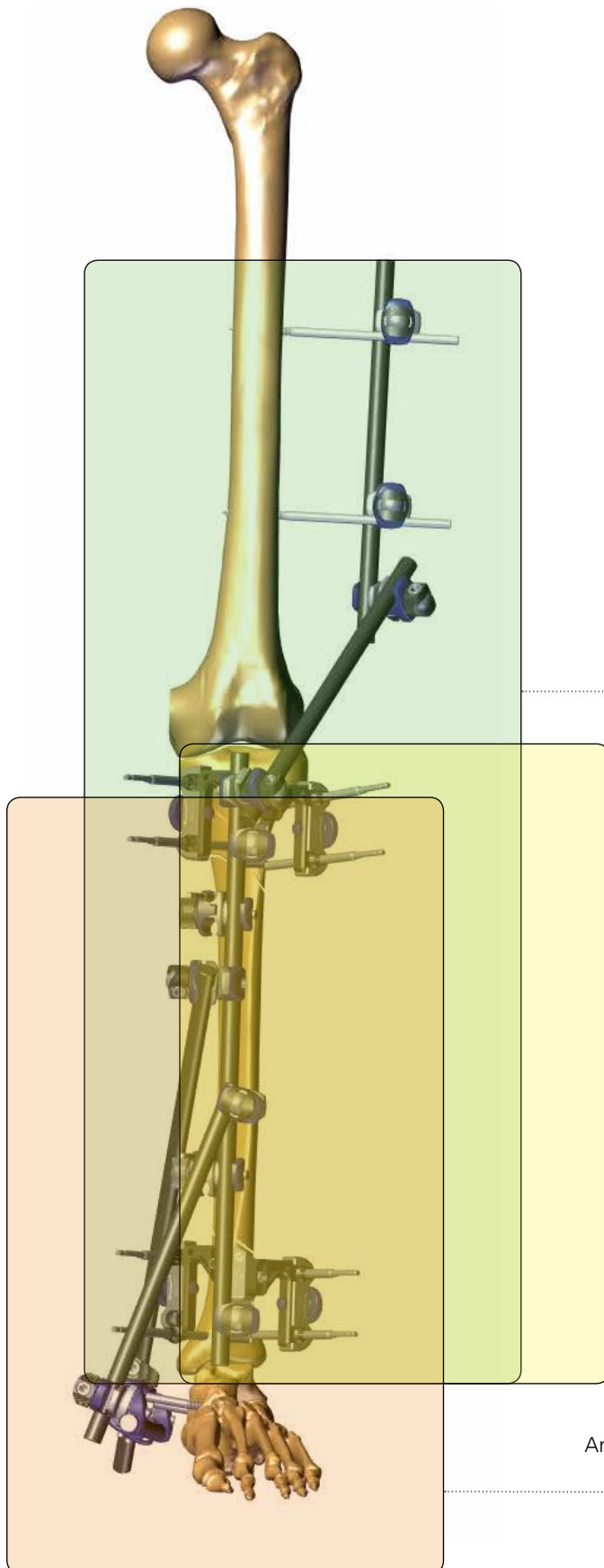

Knee spanning configuration for periarticular fractures or ligamentous injuries of the knee *

Tibial application for peri-articular, diaphyseal or segmental fractures (as shown)

Ankle spanning configuration for periarticular fractures or ligamentous injuries *

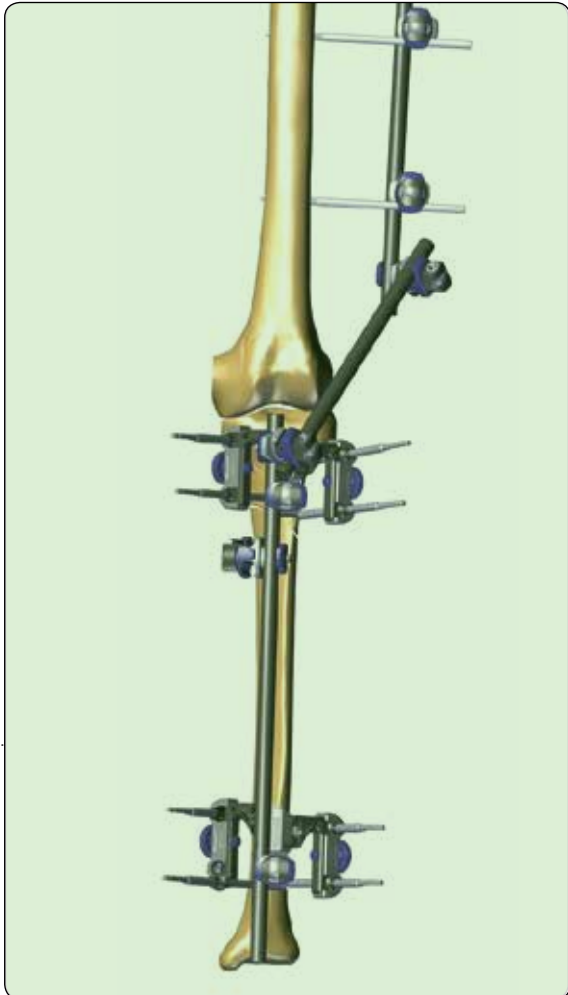

Knee spanning configuration for proximal tibial fracture associated with ligamentous instability of the knee.

Standard configuration for mid-shaft fracture of the tibia.

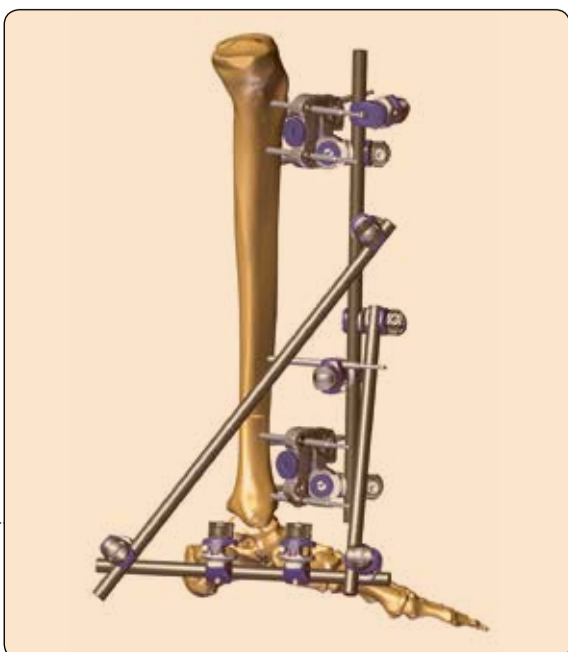

Ankle spanning configuration for distal tibial fracture associated with ankle joint instability.

* NOTE: In case of knee and/or ankle spanning, stabilization in the femur and foot must be performed with bicortical screws in conjunction with Galaxy Fixation System.



Manufactured by:
ORTHOFIX Srl
Via Delle Nazioni 9, 37012 Bussolengo (Verona), Italy
Telephone +39 045 6719000, Fax +39 045 6719380



Distributed by:

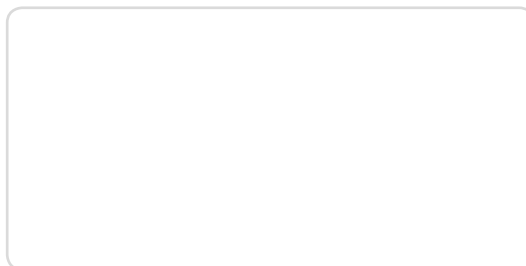

Instructions for Use: See actual package insert for Instructions for Use.

Caution: Federal law (USA) restricts this device to sale by or on the order of a physician. Proper surgical procedure is the responsibility of the medical professional. Operative techniques are furnished as an informative guideline. Each surgeon must evaluate the appropriateness of a technique based on his or her personal medical credentials and experience. Please refer to the "Instructions for Use" supplied with the product for specific information on indications for use, contraindications, warnings, precautions, adverse reactions and sterilization.

www.orthofix.com
www.galaxyunyc.com

MC-1401-OPT-E0 D 09/15

